



— MODEL — **353GF**

Pressure Control Coupler



- **Conforms to API Bulletin 1584 Third Edition**
- **Pneumatic or Hydraulic Deadman Options**
- **Accurate Nozzle Pressure Regulation**
- **Excellent Surge Pressure Control**
- **Deadman and Fuel Sense Connections Conveniently Located**
- **Bleed Valve(s) supplied, on the Pilot Block**
- **Standard Folding Operating Lever**

The Model 353GF Pressure Control Coupler is a hydrant coupler used in jet aircraft refueling operations. It connects to a hydrant pit valve or hydrant pit adapter to allow pressurized fuel to flow from an underground pipeline and into the receiving aircraft. It incorporates a Deadman operated, direct acting pressure regulator that protects the receiving aircraft from excess pressure and from damage due to pressure surges.

The Model 353GF Pressure Control Coupler has been designed and tested to conform to all requirements of API 1584 “Four Inch Hydrant System Components and Arrangements”, Third Edition. The Coupler makes a very robust connection to any 4 inch API style hydrant pit valve or hydrant adapter. This connection greatly exceeds the side-pull requirements of the API Bulletin 1584. Yet, because of the use of hardened Stainless Steel balls to make this connection, the Coupler can easily turn when connected to remove stress on the intake hose connected to the outlet of the Coupler.

The Model 353GF Pressure Control Coupler incorporates a pressure regulating valve that is deadman operated. The Coupler can be configured to accept either compressed air (Option A) or pressurized fuel (Option H) as the motive deadman fluid. Connection points for both the deadman signal and the feed-back fuel sense signal are conveniently located on the Pilot Block on the top of the Coupler. These connections are also positioned to reduce the stress on deadman and fuel sense hoses.

Additionally, Bleed Valves are provided on the side of the Pilot Block so that entrapped air in the Fuel Sense hose and Hydraulic Deadman hose (if Option H is selected) can easily be purged. These Bleed Valves feature an outlet sized for a 1/8 inch diam-

eter hose that can be slid onto the outlet of the Bleed Valve to direct the bled fuel into a catch container, thereby eliminating fuel spillage during the purging.

When pressure is applied to the deadman port on the top of the Coupler, the pressure regulating valve opens to allow flow into the receiving aircraft. The opening time is controlled by a fixed, non-adjustable orifice, conforming to the requirements of API 1584. Failing (relieving) the Deadman pressure causes the Model 353GF Pressure Control Coupler to close. For Couplers with Option A (Air Deadman), the closing time is adjustable beyond a range of 0.5 second to 2.0 seconds. This adjustment is located on the side of the Pilot Block on the top of the Coupler. For Couplers with Option H (Hydraulic Deadman), closing time is a function of the Deadman plumbing system on the refueling vehicle.

The Model 353GF Pressure Control Coupler is a remote sense regulator. It controls the pressure connected to the Fuel Sense port on the top of the Coupler. Ideally, the Fuel Sense source will be a Venturi that is adjusted to simulate the pressure in the refueling Nozzle connected to the receiving aircraft. (Otherwise, the Fuel Sense source should be as close to the Nozzle on the refueling vehicle as is practicable.) This “Nozzle pressure” is then adjustable by regulating the Deadman

pressure. Raising the Deadman pressure increases the Nozzle pressure. The difference between the Deadman pressure and the resultant Nozzle pressure is about 20 psig.

The Model 353GF Pressure Control Coupler is supplied with a Folding Operating Lever. The Lever is spring loaded so that it folds against the body of the Coupler when not in use to prevent damage during handling and transportation.

The Cla-Val Model 353GF Pressure Control Coupler is designed and constructed of high strength aluminum and stainless steel. Both the large and small pistons within the Coupler are made of stainless steel, a Cla-Val exclusive, providing for superior, long lasting sealing and a high level of durability. It also utilizes the latest in low friction seal technology to ensure accurate operation. The overall pressure drop through the fully open Model 353GF Pressure Control Coupler is the lowest available.

This allows for the fastest possible refueling cycles.

Specific additional equipment is required for Couplers with Option H, Hydraulic Deadman. See Cla-Val document number 206396 “Installation Instructions and Required Equipment” for more information.

353GF PRESSURE CONTROL COUPLER TO FIT 4 INCH API STYLE HYDRANTS

Dimensions (inches)

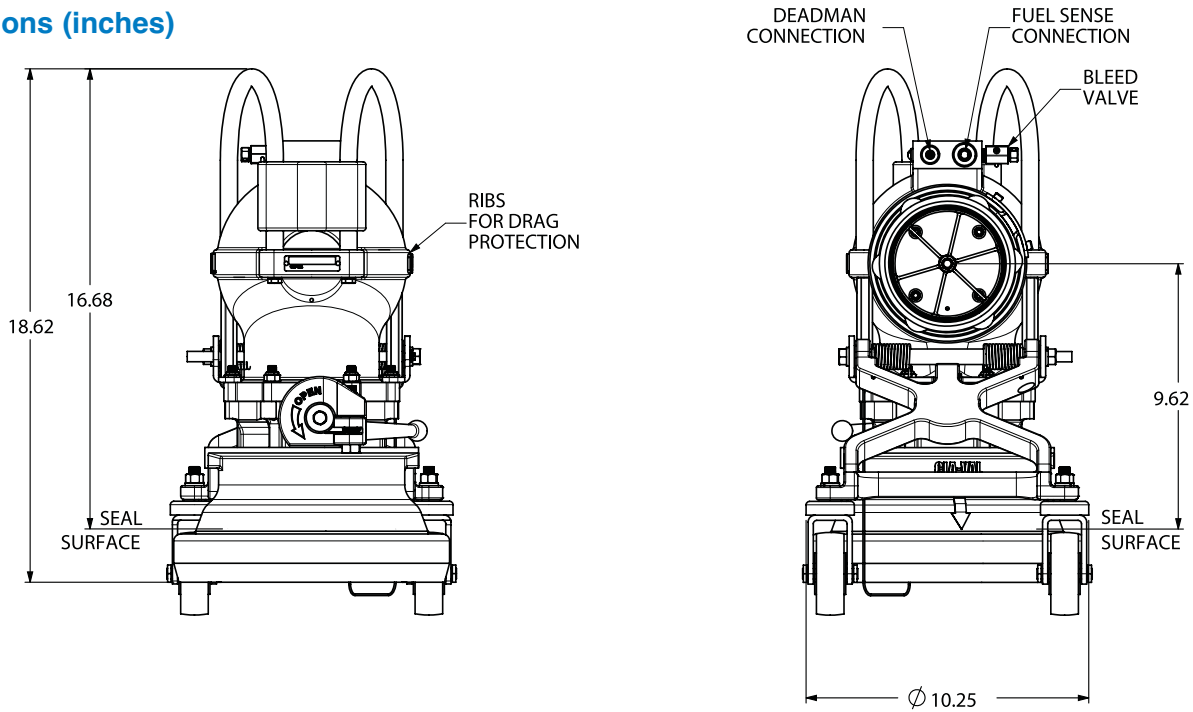

MODEL NUMBER SCHEME: 353GF-

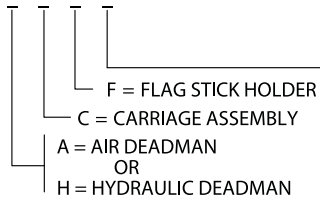

- 2B=2.5 INCH BSPP OUTLET THREAD
- 2N=2.5 INCH NPT OUTLET THREAD
- 3B=3 INCH BSPP OUTLET THREAD
- 3N=3 INCH NPT OUTLET THREAD
- 4B=4 INCH BSPP OUTLET THREAD
- 4N=4 INCH NPT OUTLET THREAD

